



## Digital Command Control



# LocoNet<sup>®</sup> and LocoNet<sup>®</sup> Cables

## Table of Contents

### Introduction

What is LocoNet?

### LocoNet Cables

Types of Cable to Use/Not Use  
Flat vs. Round Cables  
Stranded Vs. Single Conductor  
RJ Plugs

### Where to get Materials

Pre-Assembled Cables  
6-Wire Cables  
RJ Plugs  
Crimpers & Other Tools

### Manufacturing LocoNet Cables

Making the Cable

### Testing LocoNet Cables

Testing with a Network Tester  
Testing with the Digitrax LT-1 Tester  
Other Test Methods

### Repairing LocoNet Cables

### Maintaining LocoNet Cables

### References

be downloaded from the [Digitrax web site](#). This document deals with the physical specification — the cable used to carry the LocoNet signals.

For error free operation of the LocoNet in a DCC system care must be taken in the materials used, construction and interconnection of the various LocoNet cables that are used for the overall system. A fault in a LocoNet cable or cable plug, or how the network is connected together can create problems that can bring the entire system down, and be hard to trace.

The intent of this page is to detail how to manufacture, test, configure, install and repair LocoNet cables. Sources for the various materials needed are provided, as well as detailed instructions. In each step of the way reasons are provided for doing things the recommended way. Many photos and illustrations aid in understanding the instructions.

Care of LocoNet cables before, during, after and between train shows is also important as the RJ plugs can be easily damaged, or a wire in the cable broken. This topic is also covered, but requires someone to have the responsibility for the care and maintenance of the cables.

## Introduction

Two communications buses are inherent to every DCC system — the track bus and cab bus. The track bus is the means by which DCC instructions (in the form of data packets) are communicated from the DCC Booster(s) to decoders via the track. Specifications for the track bus are contained in the DCC Standards and Recommended Practices developed and issued by the National Model Railroad Association (NMRA), and can be accessed on the NMRA's web site at [www.nmra.org/standards/sandrp/consist.html](http://www.nmra.org/standards/sandrp/consist.html). They apply to all DCC systems.

The cab bus is the communications bus between the various components of a DCC system that are not part of the track bus. These include communications between throttles and the Command Station, Boosters, detection systems, signaling systems, radio/IR receivers, etc. There are no NMRA Standards or Recommended Practices for the cab bus, so each DCC manufacturer can choose the type of communications used for this purpose, and each of the major DCC manufacturers has done just this. Thus the various system cab buses are different so there is no interoperability between DCC systems at the cab bus level as there is at the track bus.

Since most NTRAK clubs have adopted the Digitrax DCC system and the pages of this web site are dedicated to the Digitrax DCC system only the Digitrax cab bus, called LocoNet<sup>®</sup>, will be addressed. There will not be a comparison with other system cab buses either at the technical level or as to which is a better choice.

The Digitrax cab bus, LocoNet, has both an electrical and a physical specification. The electrical specification and properties of LocoNet are defined and controlled by Digitrax; a technical description of LocoNet can

Care up front in manufacturing and testing is well worth the effort. You can do the work well once and care for the LocoNet cables, or you can end up doing the work many times over to fix what was not done right the first time.



## What is LocoNet®?

LocoNet® is a peer-to-peer distributed network system on which all devices can monitor the network data flow. The network is event driven by different devices in time, and is not polled by a centralized controller in normal operation. LocoNet is a powerful decentralized and scalable distributed system.

LocoNet is a proprietary Digitrax communications network especially designed for model railroad operation to provide rapid response even when many throttles and other devices are connected to the network — the communications or cab bus. LocoNet is a peer-to-peer Local Area Network (LAN) and is based on the Ethernet CSMA/CD (Carrier Sense Multiple Access with Collision Detection) Local Area Network protocol, the most universal worldwide hookup standard for computer networks. LocoNet has been optimized for use with Digitrax systems to allow 100% traffic capacity with less than 0.33% collision rate.

LocoNet is the method of interconnecting all parts of a Digitrax DCC system, such as the Command Station, Boosters, Radio and I/R Receivers, Throttles, Universal Panels, Fixed Decoders, Detectors and Signals. It does not connect to Mobile and most Stationary Decoders, which are "connected" via the track. Note that LocoNet does connect to the Digitrax DS64 stationary decoder and to the SE8C signal decoder.

The LocoNet design allows very simple free form wiring, which makes adding extra devices and features simple, and provides expandability so new features can be added by simply connecting and overlaying the capabilities to an existing LocoNet system. LocoNet cannot, however, exceed 2,000 feet in length from the Command Station.

LocoNet cables utilize 6-wire telephone/data-type flat or round wire with RJ12 plugs on each end. They can be purchased ready-made or easily manufactured to meet individual needs. The actual wiring of the LocoNet is a balanced RF Quad configuration, which is what allows the free-form non-terminated architecture.

The full implementation of LocoNet uses a 6-pin USOC (Unified Service Ordering Code) RJ12 style telco connector. The network is designed to operate "daisy chained" on unterminated 26AWG 3-pair cable or flat 6-conductor type 120-ohm impedance ribbon cable. It is designed to be tolerant of the cabling environment and can be cabled in numerous variations. The connections are balanced to minimize Radio Frequency Interference (RFI). The connections may be branched in any combination to yield a "star" or "bus" or any combination thereof. Only a single LocoNet current termination is needed and this is typically supplied by the system "master" — the Command Station.

Using typical 6-conductor telephone flat ribbon cable, a network may typically have a total parallel cable length of up to 1,200 feet, with no point-to-point length exceeding 600 feet. These limits are due to electrical requirements of the signals carried on the cable. For full technical details on LocoNet refer to the LocoNet Personal Use Specification on the [Digitrax web site](#).



## LocoNet Cables

LocoNet cables utilize 6-wire telephone/data-type cable with RJ12 plugs on each end. They can be purchased ready-made from a number of DCC dealers and hobby shops, and from Radio Shack, Lowe's, The Home Depot, Wal-Mart or other electrical or electronics suppliers, or easily manufactured to meet individual needs. 6-wire cable is available as a flat cable or as a round cable — for our model railroad purposes, flat cable is much easier to work with.

Be very careful not to use 4-wire cable, as anything less than 6 wires will not work.

In a 6-wire flat configuration, looking at the RJ12 plug, the left 3 wires are essentially a mirror image of the right 3 wires. There are 2 ground and 2 LocoNet data connections, so the effective wire resistance is lower due to paralleled wires, which increases the maximum permissible length of LocoNet cabling. It also means that if a ground or signal connection is broken or intermittent the network can still maintain a reliable connection. (Broken or intermittent wires in a cable are among the most difficult faults to trace and fix.)

The two outside wires carry opposite phase copies of the master system rail packets, called RAIL SYNC. Because these are broadcast differentially in the single cable, a remote Power Booster can be accurately and reliably connected in anywhere along a LocoNet cable run. The RAIL SYNC wires also provide the power for devices connected to LocoNet.

The 6-wire cable is configured as follows:

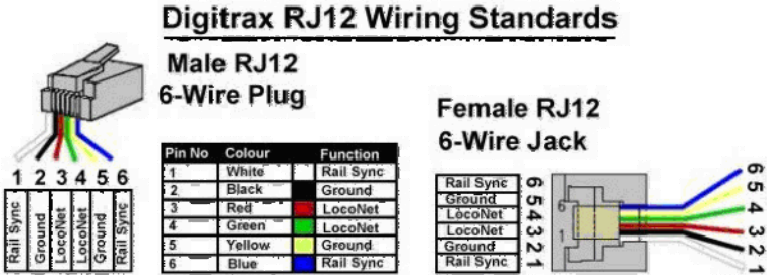

Since a LocoNet cable is a balanced symmetrical cable the polarity of pins 1 and 6 are not important unless the LocoNet loops or closes back in on itself, like a snake biting its tail. Thus the individual LocoNet cables can be straight cables (like telephone cables) or reversed cables (like data cables) — but see additional explanation below.

It is highly recommended that you select a single cable type, however, and stick with that type throughout your LocoNet, as this will minimize any potential problems. *Data-type cable is preferred since it is the best for connections from the Command Station to Boosters.* Also, telco-type cable should not be used to connect a UR90/UR91 Receiver to a Command Station, since pins 3 and 4 are not electrically connected at Command Stations and UR receivers, nor should it be used to connect to a BDL16x. If a telco-type cable is used, data may be lost since there may be no receive capability on the wire on which the data is transmitted.

**Note:** There may be cases when it can be expedient to use a telco style cable in the LocoNet. When such cables are made they should be clearly marked as such, either with a tag or colored tape at each end.

Telephone-type cable and data-type cable are essentially the same cable. What is different is how the RJ12 plugs are positioned on the cable — normal or reversed.

If you take a Telco-type or modular phone cable and lay it out flat, the connectors on each end are in the same orientation. That is, both face up or down in relation to the locking tab. This causes the cable to reverse the polarity of the cable. That is, pin 1 connects to 6, 2 to 5, 3 to 4 on the opposite end. This is a normal or straight phone cable.

On a data-type cable, laid out flat, the connectors are of the opposite orientation on each end. That is, one end faces up and the other faces down, as shown below. This causes the cable to keep the same polarity. That is, pin 1 connects to 1, 2 to 2, 3 to 3, 4 to 4, 5 to 5 and 6 to 6 on the opposite end. This is a reversed or skewed cable. Even though it is called reversed, this is only in relation to the connectors; the wires are always straight and pin 1 is always connected to pin 1 on the other end.



Data-type Cable Configuration

Note that most flat 6-wire cable has a tiny, single rib down the middle of one side. When making cables be sure to have the rib side up for one RJ plug and the rib side down for the other.

You can also determine how a cable is wired by holding both end connectors of the cable side-by-side facing the same direction. In a data-type cable the colors are the same left-to-right. In a telco-type cable the colors of the conductors are mirror-image.

In summary:

Cable Type	RJ12 Plugs	Wire Polarity
Telco	Normal	Reversed
Data	Reversed	Same

Telephony-type cable, either flat or round, is generally 26-gauge, but anything in the range of 22-gauge to 28-gauge is OK. Be consistent. It will help when you have troubleshooting and fixing to do.

Digitrax chose to use telco-type RJ12 connectors for LocoNet. Other options, some of which are used by other manufacturers, include the ¼" stereo-type phone jacks and plugs and the DIN-series of jacks and plugs, both of which are physically stronger than the RJ12. However, the RJ12 is a well-proven connector due to its almost universal use in the telecommunications industry (RJH, RJ11, RJ12, and RJ45). Its weakest part is the locking tab which can be easily broken.

No connector can be replaced as quickly as the RJ connector, which is a major consideration if one breaks during an operating session or at a train show. The RJ12 connector on a throttle or a LocoNet cable can be replaced in 30 – 60 seconds.

### Types of Cable to Use / Not Use

The cable used for LocoNet is a communications cable, but there are many different communications cables available. Clearly any cable that does not have at least 6 conductors is not acceptable. That narrows the field only slightly. Telephony cables can be flat or round, and have either two, four or six conductors. Six-conductor telephone cable is the correct and best cable to use for LocoNet.

While communications cables with more than six conductors (such as 8-conductor Ethernet cable, 25-conductor serial cable, etc.) can be adapted for use with LocoNet, their electrical characteristics are not suitable. The voltages do not match, the pinout does not match, the cabling is different, the RJ plug is different, the protocols are different and the cable capacitance is different, generally too high. Use of such cables will draw down the LocoNet voltage too much, and when the LocoNet voltage drops too low performance can become flaky. The bottom line — **use only 6-conductor telephone cable for LocoNet.**

### Flat vs. Round Cables

6-conductor telephone cables are available as flat cables or round cables. Flat 6-conductor cables are by far the easiest to manufacture and use for our LocoNet applications. The only application for which a 6-conductor round cable is recommended is the installation of a LocoNet bus on each module; this application is not covered on this page.

### Stranded vs. Solid Conductor Cables

Stranded conductor cables are flexible and easily bent to fit the routing of the cable. Solid conductor cables are rigid and are intended where the cable will seldom or never be moved after installation. The analogy to the 120V electrical cables in your house is that the wiring inside the walls is solid conductor since it will never move after installation, while the power cords on your lamps and appliances are stranded conductors and thus flexible. Too much flexing of a solid conductor cable can cause the conductor to break.

6-wire flat telephone cables use stranded wire and thus are well suited to LocoNet applications where the cables are installed and removed as layouts are set up and taken down. Since the LocoNet bus cable on a module will not normally be moved after installation, solid conductors present no problems so the use of round 6-wire cables for this purpose is acceptable.

## RJ Plugs

RJ (Registered Jack) connectors were developed by Bell Telephone Laboratories (BTL) for telephone applications in the late 1960s, and are registered with the Federal Communications Commission (FCC). As data communications technology developed the industry added to the RJ standards.

The RJ standards refer to the way the plug (or jack) is wired and what the wiring is used for, not to the physical size of the plug (or jack). The RJ standards specify the number of *cables* (wires) going into the plug (or jack) and the number of *positions* available in the plug (or jack) to anchor the wires. For our LocoNet cables we need RJ plugs with 6p6c, that is six positions (6p) available to anchor the six wires (6c). Examples of common RJ connectors and their application are shown in the table below.

Type	Use
RJH	4p4c connector used for telephone handset cords
RJ11	6p2c connector for telephone line cords
RJ11 or RJ14	6p4c connector for telephone line cords
RJ12	6p6c connector for electronic/digital telephones and LocoNet
RJ45	8p8c connector for ISDN lines, and for Ethernet 10BaseT and 100BaseT

### Examples of RJ Connectors

From the table note that there are three RJ connectors with 6p, and all three are the same physical size. When purchasing RJ plugs for LocoNet be sure you get the 6p6c variety — you can easily determine this by looking at the contact end of the plug, which should have 6 contacts visible. Also, Radio Shack refers to their 6p6c RJ plugs as RJ25.

Also, be sure the RJ 6p6c plug you purchase is designed for use with flat cable or round cable, as appropriate for the type of cable you are using. The plug is different for the two types of cable.



## Where to Get Materials

Materials and tools needed to manufacture LocoNet cables, as well as pre-manufactured LocoNet cables are readily available, both locally to most people and by mail order via the Internet. Like anything you purchase you need to ensure you purchase good quality products that do what you want them to do. LocoNet cables made with inferior wire, plugs or crimped with an inferior crimper can cause no end of problems that are hard to trace.

For model railroaders the use of 6-wire flat cable for LocoNet provides the best solution to our needs. The remainder of this page deals only with 6-wire flat cable and components for LocoNet.

### Pre-Assembled LocoNet Cables

Pre-assembled LocoNet cables, either standard lengths or made-to-measure, are available from several sources such as your local hobby shop. The following DCC mail-order dealers also provide LocoNet cables in the lengths you desire:

Dealer	Contact
Charleston Digital Trains	<a href="http://www.charlestdigitaltrains.com">www.charlestdigitaltrains.com</a>
Litchfield Station	<a href="http://www.litchfieldstation.com">www.litchfieldstation.com</a>
Southern Digital	<a href="http://www.sodigi.com">www.sodigi.com</a>
Tony's Train Exchange	<a href="http://www.tonystrains.com">www.tonystrains.com</a>

Atlas manufactures a signaling system in N, HO and O scales that uses 6-wire flat cable for interconnecting the various parts of the system. These cables can be used for LocoNet, and are available in three lengths. Cyberguys.com also have 6-wire flat cables in the same lengths.

Length	Atlas Cat. No.	Cyberguys.com Cat. No.
7'	230	180 0350
15'	231	180 0360
25'	232	180 0370

Pre-assembled 6-wire cables are also available from suppliers such as Radio Shack (Cat. No. 279-422), Lowe's, The Home Depot and other home centers. These pre-assembled cables are usually in only a single length, such as 25'. The cables are also telco cable rather than data cables.

### 6-Wire Cable

6-wire flat cables are available from many sources including Radio Shack, Lowe's, The Home Depot, Wal-Mart and other local electrical/electronic stores, usually in spools of either 25' or 100'; these cables are usually white or silver. Spools of 6-wire cable in silver, white or black up to 1000 feet long are available from electronics distributors such as Digikey ([www.digikey.com](http://www.digikey.com)) and Mouser ([www.mouser.com](http://www.mouser.com)), among others. These spools can be cut to whatever length is desired for the application.

### RJ Plugs

RJ plugs are available from the same vendors as 6-wire flat cable. There are two very important factors to remember when purchasing RJ plugs:

- No matter whether the vendor labels the plugs as RJ11, RJ12 or RJ25 make sure that the RJ plug is 6p6c, i.e. it has 6 positions and 6 contacts. Look at the end of one of the plugs and count the contacts.
- Be sure the pack of RJ plugs is intended for **flat** 6-wire cables. The RJ plugs for round 6-wire cables are different.

### Crimpers, Testers and Other Tools

The key to a good LocoNet cable is a good crimping tool. Purchase only the best crimper. Avoid any plastic crimpers. Good crimpers are available for \$35 – 45 at electronics stores, Lowe's, The Home Depot and the mail order electronics distributors. An example of a very good crimper is the Ideal Telemaster Model 33-700 shown below. This was purchased for \$40 at Lowe's.



#### Ideal Telemaster Model 33-700 Crimper

This crimper will properly crimp 2, 4 and 6-wire RJ11/12/25 stranded modular plugs and also RJ45 8-wire stranded modular plugs. It contains blades for cutting a 6-wire flat cable, as well as a blade for cutting off the sheath at the correct length from the cable end for proper crimping. Replacement cutting blades are available from the manufacturer.

Other equivalent crimping tools are available from other vendors. Do not purchase the Radio Shack Cat. No. 279-388 Crimping Tool (\$9.99). This tool is made of plastic and is fragile. Its main deficiency is that it is designed for 6p4c plugs only, not the 6p6c required for LocoNet. Purchase a crimping tool like the one shown above.

The only other tool you may need for manufacturing LocoNet cables is standard electrical wire cutting pliers (diagonal cutters), available at almost any hardware or home supply store.

For testing LocoNet cables you will need two tools — a network cable tester and the Digitrax LT1 tester.

The **Network Cable Tester** is an excellent tool for testing newly manufactured LocoNet cables and for verifying the integrity of LocoNet cables before installation on a layout. Most network cable testers have four LEDs that allow for testing up to 4-pairs of wires; they can be used to test Ethernet cables as well as 6-wire LocoNet cables. For our 6-wire LocoNet cables only 2 of the 4 LEDs will light — green for a good data cable, and red for a good telco cable.

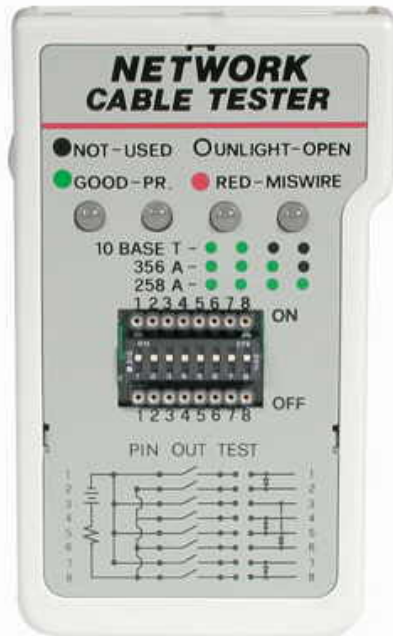

This is a Hobbes Model 251450 Network Cable Tester. It is available from [CablesToGo](http://CablesToGo) and other vendors. MSRP is \$49.99, but it is frequently on sale for as low as \$25.00. The RJ jacks allow testing of cables with RJ11, RJ12, RJ25 and RJ45 plugs. For 6-wire cables only the inner two LEDs will be active. The tester requires a 9V battery. For our LocoNet testing purpose the DIP switches are not used; their settings are irrelevant.

#### Network Tester

The **Digitrax LT1 Tester** is primarily used for testing LocoNet cables that are already installed in a layout. The number and combinations of LEDs that light provide an indication of the cable's integrity, as described in the section on Testing.

Photo Source: Digitrax, Inc.



#### Digitrax LT1 Tester

## Manufacturing LocoNet Cables

To repeat, LocoNet uses 6-wire modular cable. There are two types of modular cable — Telco and Data. The cable is the same basic cable for both types. What is different is how the ends (RJ-type plugs) are positioned on the cable — Standard or Reversed.

Except as noted below, it does not matter whether you wire your LocoNet with Data or Telco cables. With a telco cable the polarity of the LocoNet changes with each cable connection in a daisy chain. With a data cable the LocoNet polarity remains the same with each connection in the daisy chain. Pay close attention to the following two exceptions:

- A data-style cable must be used to connect a UR90/UR91 to a DB150, DCS50, DCS100 or DCS200 Command Station/Power Booster, unless you have a shorting plug (pins 3 and 4) somewhere in the LocoNet or any throttle plugged into LocoNet. This is because these devices communicate on pin #3 only.
- Select the cable type for the connection between Power Boosters such that the Boosters all power up in the same phase (Information on testing Power Booster polarity follows.)

The following descriptions relate to LocoNet cables manufactured from 6-wire flat cables.

To actually manufacture the cable you will need a crimping tool designed for RJ11/12 jacks, as described above. This tool includes a blade that strips the cable jacket insulation from the 6-wire flat cable (some crimping tools also include a blade that will cut completely through the cable). After stripping, the RJ12 connector is then inserted into position in the tool, the 6-wire cable inserted into the RJ12 connector in the proper orientation, and the wire crimped to the connector using the tool.

### Making the Cable — Flat Cable with RJ12 Plugs

The following are detailed step-by-step instructions for making a LocoNet cable using telco flat wire and RJ12 plugs. You will need the following components and tools:

Components	Tools
6-wire flat telephone cable	Diagonal wire cutters
RJ12 plugs	Crimping tool
	Cable tester

To make the cable, do the following:

- Using the diagonal wire cutters (or the crimping tool blade that will cut through the cable, if your tool has that blade), cut the 6-wire telco flat cable to the desired length. Be sure the cut is at right angles to the cable and the end is smooth where the cut was made.
- Insert one end of the cable into the cable jacket stripping blade of the crimping tool. Squeeze the handle and then carefully pull out the 6-wire cable from the tool. This operation removes the cable jacket exposing the 6 conductors. Be sure the ends of the wires are even; if necessary, make them even using the diagonal wire cutters. Spread the wires apart just slightly to ensure they will fit properly into the RJ12 plug.
- Slide the RJ12 connector onto the wires, making sure the wires stay lined up. The connector has six slots, one for each wire. Try to make each wire reaches the end of its slot. The cable jacket/insulation should reach just beyond the end of the crimp point. If the jacket doesn't reach far enough inside the connector, cut the wires off just a bit more. If the cable jacket/insulation reaches too far past the crimp point or if the wires don't reach the end of their slots, simply trim off a little more jacket/insulation.

For the RJ12 connector to be very reliable it is very important to ensure the cable jacket is inserted into the clear body of the connector. This is the only strain relief these frail wires will receive. If you fail to do this, the connector will, sooner or later, fail and get you into trouble.

The photos below show the difference between a good crimp and a bad crimp:

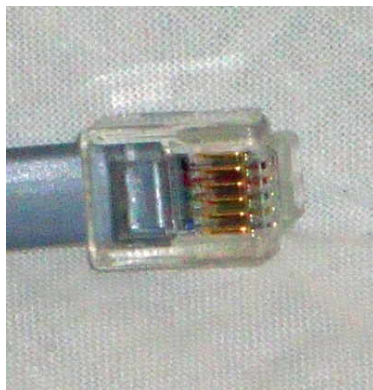

Good crimp  
Jacket inside plug

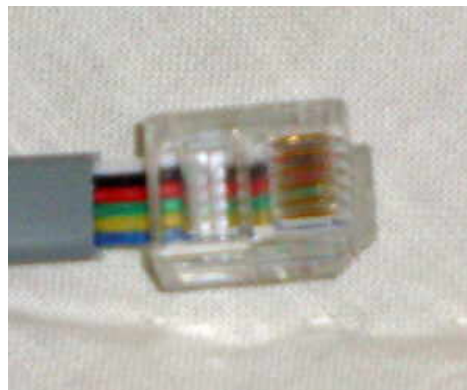

Bad crimp  
Jacket not inside plug

Whether the blue wire or the white goes is on the left really doesn't matter. What you must be is consistent. If you always have the same color cable on the left at both ends of the cable you are constructing a data-type cable, the preferred type.

If you have one color on the left at one end of the cable and the other color on the left at the other end of the cable, you will construct a telco-type cable.

- Again verify that all is in order and insert the connector into the crimping tool. Crimp it. This requires a little bit of strength, and you may need to use two hands.
- Repeat the previous steps for the other end of the cable.
- Test the cable to make sure it works properly.

If using a network cable tester (recommended) plug both ends of the cable into the tester. If both LEDs light green the cable is a good data-type cable. If both LEDs light red the cable is a good telco-type cable. If no LEDs light or they light in any other combination the cable is faulty. Wiggle the cable near the RJ plugs; if the LEDs flicker or go out then the cable is faulty. Try to determine which RJ12 connection is incorrect, cut it off and replace with a new RJ12 plug.

If using a Digitrax LT1 tester, plug one end of the cable into either the LocoNet A or B jack on the Command Station, and plug the other end into the LT1. The LEDs on the LT1 should light. Refer to the "Testing" section below for the correct interpretation of the LT1 LEDs.



## Testing LocoNet Cables

If strange things happen when plugging in a LocoNet cable, such as throttles going to "Idle," Boosters shutting down and track status lights going out, it is likely there is either a shorted cable or crossed wires in the RJ connector at the ends of the cable. A key is to note whether the condition is caused when only one end of the LocoNet cable is plugged in, which indicates a short circuit, or when both ends of the cable are plugged in, which indicates an open circuit. Test the cable as described below, and repair or replace either the cable or one or both of the RJ connectors.

All newly manufactured LocoNet cables should be tested before being used on a layout. Ideally, all LocoNet cables should also be tested before being installed in a layout.

Several devices are available for testing LocoNet cables. Which one you choose will depend on the amount of use and the cost. These testers include: a Network Cable Tester, Digitrax LT1 Decoder/LocoNet Tester; an Ohmmeter and a DT-type Throttle. Each will be discussed along with how to perform the tests.

In almost all cases when a fault is found in the cable, the remedy is to replace one or both RJ12 connectors. Test again once the connector(s) have been replaced.

If the following tests and careful replacement of the RJ12 connectors fail to find the problem with a LocoNet cable, it may be possible the cable itself is defective — this is rare but does happen. This is easiest to spot if you are using flat modular type cable. Visually examine it, then use your fingers to feel for strange humps in the cable (which should be fairly smooth and flat). A hump means either the wires got twisted inside the sheath or the manufacturing process made a mistake when making the cable.

### **Network Cable Tester**

A commercial network or LAN cable tester, such as the Hobbes tester shown earlier, can be used if it is able to check 6-conductor as well as the normal 8-conductor LAN cables. You plug both ends of the cable into the tester. If both tester lights glow red (indicating a telco-type cable) or green (indicating a data-type cable) the cable is good. While the RJ connectors are plugged into the tester, wiggle the cable near each connector to check for intermittents — the light(s) will flicker if an intermittent condition exists. Using a network tester is rapid and easy, especially if you are in the cable manufacturing business for a large layout. It is the only quick way to test both ends of the cable at once.

The following photo shows a test of a "good" LocoNet cable:

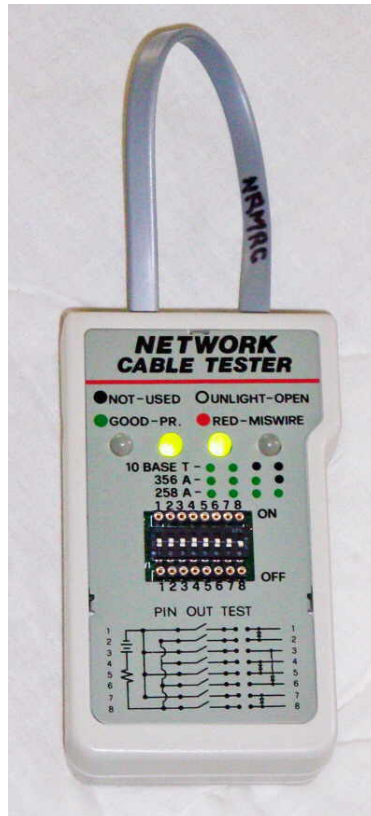

### ***Digitrax LT1 Decoder/LocoNet Tester***

For testing LocoNet cables already mounted and connected in a layout the simplest and best way is to use the Digitrax LT1 Decoder/LocoNet tester, which is supplied with all Digitrax starter sets or can be purchased separately. (It is not a great decoder tester, but indispensable as a LocoNet tester.) It can also be used for newly manufactured cables, but it is not as good as the network tester for that purpose.

Because of the way LocoNet is designed, you could actually have 1, 2 or even 3 defective wires and it could still work. While this is great for reliability during an operating session, having defective conductors lowers that reliability and exposes you to future failure, probably at the most inopportune time. Such a failure could also result in symptoms that might not be related initially to LocoNet.

The LT1 has four LEDs and an RJ12 jack mounted on a PC board. Using a known good cable to plug into the LT1's jack, you can then plug the other end into the Command Station's LocoNet jacks or any other jack on the network. The [test procedure](#) is to start at the Command Station and then work out the LocoNet segment-by-segment until the fault is found. Repair or replace the faulty connection or cable, and then check again with the tester to ensure it is correctly fixed.

If you have an extensive LocoNet network this can be very time consuming. Alan Gartner provides a method of quickly narrowing down the problem. Check it out on his [Wiring for DCC](#) web site (Track Wiring Section, Troubleshooting 5 21 option) at [WiringForDCC.com](#).

To be able to obtain all 4 LEDs lighting there must be a DT-type throttle plugged into one of the Command Station jacks, and Track Power must be ON so Rail Sync signals are present on pins 1 and 6.

The LT1 has four LEDs, numbered 1 to 4, from left to right when looking at the LT1 from the LED end. The LED's check for the proper voltages. These are:

LED#1	Pins 1 and 2	
LED#2	Pins 2 and 3	
LED#3	Pins 4 and 5	
LED #4	Pins 5 and 6	

Wires 1 and 2 power LED#1, and wires 2 and 3 power LED#2. Since the wire 2 is common to both LEDs, both LEDs will be off if that wire is defective. If only one of those two LEDs is off, its respective wire is defective. (If both wires 1 and 3 are defective, both LEDs will be off, possibly making you think it's the wire 2.)

If only one of those two LEDs is off, it is the respective wire for it, but if both of those LEDs are off, it could be the wire 2, both wires 1 and 3, or all three.

Wires 4, 5 and 6, with the wire 5 being common, work the same way with the other two LEDs.

In summary, with the LT1:

- LED#1 lights if wires 1 and 2 are good.
- LED#2 lights if wires 2 and 3 are good.
- If LED#1 and LED#2 are both off, wire 2 is bad, or both wires 1 and 3 are bad, or all three wires are bad.
- LED#3 lights if wires 4 and 5 are good.
- LED#4 lights if wires 5 and 6 are good.
- If LED#3 and LED#4 are both off, wire 5 is bad, or both wires 4 and 6 are bad, or all three are bad.

If the LocoNet works, an LED being off will usually indicate a break in the indicated wire. If the LocoNet does not work, an LED being off could indicate a dead short circuit stealing all the power. A dim LED will usually be caused by a resisted short circuit (usually caused by a single strand crossing over in a crimp-on connector) or other current leak, rather than a bad connection or a full-on short circuit.

The best way to test an individual cable is to connect it directly to either LocoNet jack on a Command Station (DCS50, DCS100, DCS200 or DB150) and then plug in the LT1. Depending on how the cable is made either LED#2 or LED#3 will not be on. If the cable is a data-type cable, LED#3 will be off, since the Command Stations communicate only on wire #3. If the cable is a telephone-type cable, LED#2 will be off.

If the LEDs do light as they should, the solution is to cut off the RJ connectors and install new ones at each end, making sure that all wires match positions on each connector. If you check either end with an Ohmmeter, there should be no contact between any two wires.

In summary:

Condition	LEDs Lighted	Comment
OK	3	The outside Rail-sync LEDs should always light, and either one of the two inside LEDs should light
OK, Properly Phased	3	LEDs 1, 2 and 4 should light.
OK, Reverse Phased	3	LEDs 1, 3 and 4 should light.
Both LocoNet + and – shorted (Note)	4	All 4 LEDs should light.
Any Other LocoNet Device Connected	4	All 4 LEDs should light.

Note: Connection between these two lines is normal and usually provided by a plug-in throttle or other LocoNet device.

Special note: The LT1 tester is not, by itself, a LocoNet device, and should only be connected to LocoNet while testing. No LT1 tester should be left connected to LocoNet during normal operations.

#### **Note for Use of LT1 with Zephyr (DCS50) Command Station**

The LT1 works slightly differently with a Zephyr Command Station because of the built-in throttle in the Zephyr. Both LED#2 and LED#3 will always be lit because of the throttle.

Also The Zephyr will light all four LEDs when the Zephyr is first powered up, even though the Power LED on the Zephyr may be off. Cycle the Zephyr Track Power on then off and one of the outside LEDs will go out.

### **Other Test Methods**

**Ohmmeter** An ohmmeter or other continuity tester can be used to check the LocoNet cable and connectors. Consider the LocoNet cable as two 3-wire cable groups. Check for shorts against each of the groups, and for shorts between adjacent pins in the RJ connector. Also test for continuity of each pin at each end of the cable.

**Digitrax DT-Type Throttle as LocoNet Tester** This procedure utilizes a known good DT-type throttle (DT100/DT200/DT300/DT400) equipped with a known good 9V battery. The process is to start with the throttle plugged directly into the Command Station, check that throttle functions operate correctly, then move outwards in the LocoNet network checking throttle functions at each location until the fault is detected. Then repair or replace the faulty connector or cable, then test again, etc. Using a throttle is much more time consuming than any other method of testing.



## **Repairing LocoNet Cables**

The vast majority of LocoNet cable faults are related to the RJ12 plug on the ends. The locking tab breaks off or the crimp becomes loose and wires break or stop making reliable contact in the plug. The solution is to cut off the defective plug and install a new one, as described below.

For other cable faults such as a broken, open or shorted conductor the best solution is to discard the cable and make a new one. If you know with certainty where such a fault is you can cut out the bad part of the cable, then add RJ12 plugs to make two shorter cables.

### **Replacing a Broken RJ12 Plug**

RJ12 plugs on throttles and LocoNet cables occasionally break and must be replaced. The most common problem is the locking tab breaks off. Another problem is excessive strain on the wires inside the RJ12 plug causes one to break or become intermittent. Replacing the plug is easy and quick. Just do the following (which is a repeat of the process used in manufacturing a LocoNet cable):

- Note the proper wire color as oriented to the existing plug. For example, looking at the RJ12 plug on a Digitrax throttle, with the locking tab up and away from you, the blue wire is on the left.
- Cut off the damaged or failed plug as close to the plug as possible. Use diagonal wire cutters.
- Be sure the end of the cable is cut square and smooth. Use the jig built into the crimping tool to cut and remove the cable sheath back the proper distance.
- Insert one end of the cable into the cable jacket stripping blade of the crimping tool. Squeeze the handle and then carefully pull out the 6-wire cable from the tool. This operation removes the cable jacket exposing the 6 conductors. Be sure the ends of the wires are even; if necessary, make them even using the diagonal wire cutters. Spread the wires apart just slightly to ensure they will fit properly into the RJ12 plug.
- Slide the RJ12 connector onto the wires, making sure the wires stay lined up and the blue wire goes to the correct pin on the plug. The connector has six slots, one for each wire. Try to make each wire reach the end of its slot. The cable jacket/insulation should reach just beyond the end of the crimp point. If the insulation doesn't reach far enough inside the connector, cut the wires off just a bit more. If the cable jacket/insulation reaches too far past the crimp point or if the wires don't reach the end of their slot, simply trim off a little more jacket/insulation.

For the RJ12 connector to be very reliable it is very important to ensure the cable jacket is inserted into the clear body of the connector. This is the only strain relief these frail wires will receive. If you fail to do this, the connector will, sooner or later, fail and get you into trouble.

- Again verify that all is in order and insert the connector into the crimping tool. Crimp it. This requires a little bit of strength, and you may need to use two hands.
- Test the cable to make sure it works properly.

Once you have done this a couple of times, you should be able to replace an RJ12 plug in about 30 – 60 seconds.

## Connecting LocoNet Cables in the Layout

Digitrax crafted the LocoNet philosophy and architecture to allow free-form wiring with no termination or linear-bus restrictions. This means that you can "star", "tee" into, branch or expand the network any way that is convenient and meets the requirements of the specific layout. The network topologies that can be used are:

<p><b>Star Topology</b> All devices are connected to a central hub by individual legs.</p>	
<p><b>Bus Topology</b> All devices are connected to a central cable. Also referred to as "daisy chain".</p>	
<p><b>Tree Topology</b> Combines the characteristics of both the star and bus topologies.</p>	
<p><b>Freeform Topology</b> The most practical topology for LocoNet networks. It permits any combination of topologies needed to wire LocoNet around the layout.</p>	
<p>Note: CS represents the Command Station and M represents any LocoNet compatible module or device.</p>	

Diagram source: Digitrax Inc.

LocoNet should not be looped back on itself; there is no valid reason to do this. If LocoNet is looped back on itself and the Rail Sync wires are not the same polarity all Boosters connected to the LocoNet will stop working.

LocoNet cannot exceed a maximum distance of 2,000 feet from the Command Station.

### Preparing a LocoNet Network

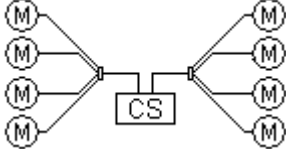
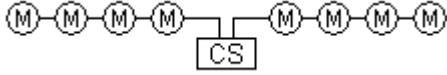
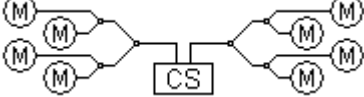
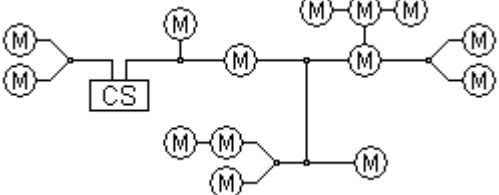
Once the layout plan is complete begin by finding the geographic center of the layout and locate your Command Station there. Then plan how you will connect LocoNet from the Command Station to the various DCC modules and devices that will be located around the layout. These will consist of Boosters, Universal Panels, Radio/IR Receivers, Power Managers, etc. The plan can be penciled in on the layout plan.

For many NTRAK layouts at Train Shows, which are rectangles of various sizes, the LocoNet plan will utilize the simple Bus Topology. LocoNet will extend in both directions around the layout from the Command Station, daisy chaining through

devices such as Boosters Universal Panels, etc. until you get to the diagonally opposite point on the layout, where the LocoNet will end. Do NOT connect the end of the two LocoNet segments together.

For larger and more complex layouts more planning will be required, and you will be using the Freeform Topology. Again, pencil in the LocoNet and other DCC devices on the layout plan.

Once you have the plan do the following:

- Determine the number and approximate lengths of the LocoNet cables you will need for the layout.
- Manufacture any cables that will be needed but are not on hand. If you are not sure of the length required make these cables on site after measuring the needed length.
- Using a network tester test all the LocoNet cables that will be used in the layout, both the newly manufactured and the existing cables. Spending the time and effort to test the cables prior to installation on the layout can save time troubleshooting later, which can take even more time and effort.
- Repair any cables that are faulty by replacing the RJ12 plug or discarding the cable, as appropriate.
- Place the tested LocoNet cables in a container for transport to the layout site in such a way that they will not become tangled or damaged.
- Make sure you also take the necessary tools and supplies to manufacture and repair LocoNet cables on site should the need arise, such as replacing a cable that gets damaged during installation or operations.

### Connection Do's and Dont's

There is one rule here — pay attention to details and think about every connection before you make it. Make sure you connect the LocoNet cable to the correct jack on the devices you are connecting from and to. For example, you should not connect a LocoNet cable from a Booster to any jack except the rear jacks on a Universal Panel, as there are no Rail Sync signals on the other jacks and the Booster will not work.

### Running LocoNet Cables

Of all the cables involved with the setting up and operation of an NTRAK layout the LocoNet cable is the most fragile and easily damaged. Thus it needs to be installed in a manner and location where it is protected from damage. Do the following:

- Suspend the LocoNet cables from the modules as you run them through the layout (using twist ties or other secure mounting). Do not allow them to lie on the floor or hang down from modules such they can be snagged by other activity around the modules (such as box storage, entry/exit from the layout, etc.).
- Should the LocoNet need to be run on the floor, it should be run down a module leg and then it must be securely fastened to the floor with suitable tape, and not be twisted underneath the tape. Avoid high traffic areas and any location where material will be dragged across the taped cable.

Extend the LocoNet around the layout as described below:

- Begin by setting up the Command Station and have it powered up and running, with a DT-type throttle plugged into one of the Command Station jacks. This will enable LocoNet testing using all four LEDs of the LT1 tester as you progress around the layout installing LocoNet cables. (The DT-type throttle is required since pins 3 and 4 are not connected in the Command Station.)
- Begin installing LocoNet cables starting at the Command Station and working outwards around the layout. When you plug the RJ12 plug into a jack make sure it is fully inserted into the jack and locked. Insert the plug, then pull it back just a bit so that it "clicks" into place.
- Test cables with the LT1 tester as you go, and resolve any problem encountered where all 4 LEDs on the LT1 do not light. You do not have to test every cable, but you should test on a regular basis (say 3 or 4 cables) to ensure there are no faults.
- Always test the cables with the LT1 tester at any branch point before going further. This ensures the installation up to that point works properly, and will make troubleshooting faults on the branches easier.

- Continue installing and testing the cables until the LocoNet network is complete.
- The maximum length of a LocoNet device from the Command Station is 2,000 feet. The overall LocoNet network, say connected in a Free form Topology can be much more than 2,000 feet, but the furthest point of any device from the Command Station cannot be more than 2,000 feet. (For example, the overall LocoNet network at a recent large NTRAK convention had more than 6,000 feet of LocoNet, but no device was more than 700 feet from the Command Station.)

### The LocoNet Repeater (LNRP)

For larger layouts the LocoNet cabling can be extensive and complex due to the size and complexity of the layout. Digitrax has developed a device called the LocoNet Repeater (LNRP) which permits the isolation and protection of segments of the layout, i.e. each branch, and acts as a diagnostic tool when problems arise. It improves the reliability of LocoNet operation for larger layouts. The LNRP and its connections are shown below. Each LNRP must be individually powered with 15–18VDC.

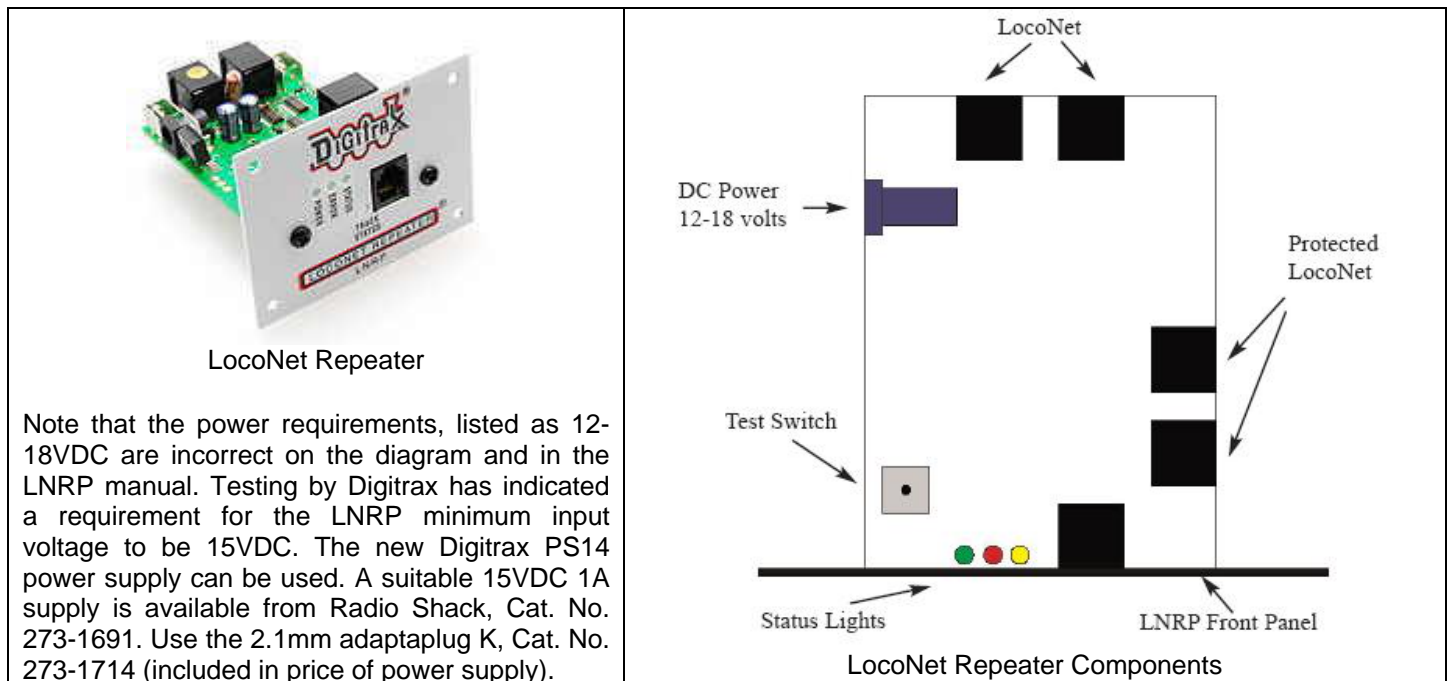

The features of the LNRP are:

- Isolates segments of a LocoNet layout.
- Protects segments of LocoNet layouts.
- Extends large LocoNet installations, especially where there are more than 20 devices.
- Acts as a Diagnostic tool if LocoNet problems occur.

Central to the operation of the LNRP is the concept of "Standard" and "Protected" LocoNet segments. A "Standard" segment is between an LNRP and end devices (UP panels, DS64s, Boosters, etc.), and are where problems might be expected to occur more frequently. A "Protected" segment is between the LNRP and the Command Station, and is "protected" from faults on the downstream standard segments by the LNRP.

If a wiring or signal problem occurs on any "standard" LocoNet section that the LNRP is connecting and monitoring, the LNRP will act to internally disconnect the faulty "standard" LocoNet segment so that the "protected" LocoNet can continue operating. If the fault is removed, the LNRP will typically automatically reconnect and resume operations on the "standard" LocoNet segment.

The LNRP boosts and separates the Rail Sync signal from the master Command Station, so if there is a problem on the downstream "standard" side of the LNRP, only the separated "Standard" Rail Sync copy on that leg is affected. The Rail

Sync signal from the master Command Station (i.e., the "Protected" Rail Sync is unaffected along with other devices that need good Rail Sync.

Similarly, the LocoNet "data" part of the cable wiring is protected to the Command Station side.

Since the LNRP drives the power and Rail Sync signals on the "standard" LocoNet cable segments each LNRP should have a DC input of +15V to +18V at up to 250mA supplied on the side DC power jack.

Much more information on the LNRP and its use with LocoNet networks is provided in the DCC Design Specification available elsewhere on the North Raleigh Model Railroad Club's web site.



## Troubleshooting LocoNet Cables

The NET indicator on the DB150 or DCS100/DCS200 Command Stations is a red LED that displays information about what the Command Station sees on LocoNet. When the LocoNet is wired correctly and is operating properly, the NET indicator will be on and it will flicker off any time a good LocoNet message is detected by the Command Station. The following table explains the various patterns for this indicator:

NET LED Indication	Meaning
Solid Red	LocoNet OK
ON, Blink Off	Command Station detects a valid LocoNet message
Off	Command Station detects a short circuit on LocoNet
OFF, Blink Every 0.5 Second	Command Station is in Option Set Up Mode

If the layout includes one or more LocoNet Repeaters the LNRP LED indicators will also provide information on the problem. LNRP fault codes are the following:

Red LED (Protected LocoNet Side)	
Off	Protected LocoNet, Rail Sync OK
One Wink	Protected LocoNet Shorted or Stuck Low
Two Winks	No Rail Sync (probably disconnected)
Three Winks	Large Capacitive Load on Protected LocoNet
Four Winks	Medium Capacitive Load on Protected LocoNet (16Kbaud only)
Yellow LED (Standard LocoNet Side)	
Off	LocoNet, Rail Sync OK
One Blink	LocoNet Shorted or Stuck Low
Two Blinks	Rail Sync Shorted to Ground or Each Other
Three Blinks	Large Capacitive Load on LocoNet
Four Blinks	Medium Capacitive Load on LocoNet (16Kbaud only)
Green LED (Power Status)	
Mostly On	DC Power Good, Rail Sync Active
Mostly Off	DC Power Good, Command Station is in Sleep Mode
Fast Blink	DC Power Out-of-Range (<12V or >20V)
<p style="text-align: center;">A Blink is defined as a light that's mostly off, and then on momentarily. A Wink is defined as a light that's mostly on, then off momentarily.</p>	

If an installed and working LocoNet starts causing problems or stops working, testing each part of the LocoNet will be necessary to isolate the problem cable or components, a process that is made easier with the protection capabilities of the LocoNet Repeater. The only tool necessary to do this is the Digitrax LT1 tester coupled with the fault codes on the Command Station NET indicator and/or the LNRP. Some faults can be better checked with a Multimeter and test probes, but for expediency it is easier to replace any suspect cable or component.

If the LocoNet is equipped with an LNRP the starting point for testing is at the LocoNet Repeater (LNRP) with the active fault indication. For all tests be sure there is a Digitrax DTxxx throttle plugged into either the LNRP throttle jack or a Universal Panel in the affected district located close to the LNRP. Following is the procedure:

- Starting at the appropriate LNRP remove one main branch of the LocoNet and plug in the LT1. All 4 LEDs should light. If less than 4 LEDs or none light the problem is in the LNRP. If all 4 LEDs light then the problem is in the LocoNet branch disconnected.
- Move out the affected branch to the end of the first cable, disconnect it and plug in the LT1 there. If less than 4 LEDs or none light then replace that cable.
- Continue along the layout spine or down the branch/loop until the LT1 fails to light or less than 4 LEDs light, and replace the bad cable. If a Universal Panel is determined to be the problem either replace it or bypass it.

If there is no LNRP in the LocoNet then start at the Command Station and work out, as described above.

When troubleshooting the LocoNet, check for the following types of problems:

- RJ12 plugs that are not fully inserted into the jacks (insert the plug, then pull it back just a bit so that it "clicks" into place).
- RJ12 plugs that have not been properly crimped, or the crimp has become loose.
- Loose or broken wires on RJ12 telco jacks.
- A less common problem is one of the pins in the LocoNet is crossed over another. Look inside each port to be sure the pins are lined up in their respective slots.
- Using 4-wire components (cables and plugs)
- Using Ethernet RJ45 components (jacks, plugs Cat 5 cables) or other computer-type cables and components
- A defective Universal Panel (UP3, UP5, other). Either replace or bypass the panel.

If it is necessary to measure, the following are normal LocoNet voltages, all measured to ground:

Wire	Color	Voltage
1	White	5 – 7 VDC
2	Black	Ground
3	Red	10 – 15 VDC Measure between the pin or wire and ground.
4	Green	10 – 15 VDC Measure between the pin or wire and ground.
5	Yellow	Ground
6	Blue	5 – 7 VDC



## Maintaining LocoNet Cables

The term "maintain" here means what happens to LocoNet cables after operations end on a layout and the next time the cables will be used in a layout. Careless removal and storage of LocoNet cables can be the source of damage to the cables. Do the following:

- Use as much care in removing LocoNet cables from the layout as you did in connecting them. When pulling cable along modules it is very easy to catch the locking tab on an RJ12 plug and either weaken it or break it off. Pulling a cable when the locking tab catches can also result in a weakened crimp.
- Do not toss a bunch of LocoNet cables in a box. They will end up tangled together and create another opportunity for damage when they are removed from the box. Carefully wrap each cable and then anchor with an elastic band before placing neatly in a box or carton. Twist ties and tie wraps could also be used, instead of an elastic band, to anchor the wrapped cable.

When coiling cables maintain a circle at least 6–8 inches across, especially if the cable has solid conductors.

- At a convenient time before their next required use, verify the integrity of the LocoNet cables by testing with a network cable tester. Repair or replace RJ12 plugs and cables as necessary. Carefully place back in the storage box until needed.

---

## References

Much of the information contained in this document is the result of direct experience learned from various large NTRAK layouts, beginning with the first uNcoNveNtioN held in Richmond, VA in 1999, and especially from the large Capitol Limited layout at Chantilly, VA in 2004 and the Derby City Express layout at Louisville, KY in 2008.

**LocoNet<sup>®</sup> Personal Use Edition 1.0 Specifications** issued by Digitrax Inc. at [www.digitrax.com/ftp/loconetpersonaledition.pdf](http://www.digitrax.com/ftp/loconetpersonaledition.pdf). October 16, 1997, and other information in the Digitrax Knowledge Base.

**"Wiring for DCC"** by Alan Gartner. A very comprehensive web-site that should answer virtually any question about wiring a layout for DCC. Also contains many valuable hints and tips. <http://www.WiringForDCC.com>

**Don Crano's "Model Railroading with DCC"**. This site has several projects and lots of hints and tips. There is also an excellent page on "What's New in the World of DCC." <http://pages.ssnnet.com/donc/>.

**DCC Mailing Lists on the Internet.** The following two email lists are directly applicable to N scale and Digitrax DCC:

Mailing List	Description
Digitrax	This is a Digitrax Users Group Chat List for those who are using the Digitrax Digital Command Control system for model railroads.
N Scale with DCC (ndcc)	All Digital N-Scalers are welcome (also Nn3, H0n3, and Z). If you post a question, please prepare and post a summary of answers. Respond directly to the questioner, not the list. WTB every day, FS every Monday.